

THE BOOK OF THE VILLIERS ENGINE

A COMPLETE AND FULLY ILLUSTRATED
INSTRUCTION MANUAL ON THE CON-
STRUCTION, RUNNING, AND REPAIR OF
VILLIERS ENGINES

WITH CHAPTERS EXPLAINING IN NON-TECHNICAL
LANGUAGE THE PRINCIPLE OF THE TWO-STROKE
ENGINE, THE ACTION OF THE MAGNETO, AND THE
CARBURETTOR

BY
CYRIL GRANGE

SEVENTH EDITION

www.podkowa98.pl



LONDON
SIR ISAAC PITMAN & SONS, LTD.

1947

www.podkowa98.pl

CHAPTER VII

THE VILLIERS CARBURETTOR

The object of the carburettor is to supply the engine with a mixture of petrol and air combined in such proportions as to make an explosive compound. Varying engine temperature and load conditions make the problem of carburation rather complex, and even the most modern instrument is really a compromise, but, nevertheless, an efficient one.

Petrol is a spirit distilled from crude oil, and having a specific gravity of .76, for the interest of those readers who are technically inclined. It is essential for this spirit to vaporize rapidly, and an efficient carburettor will help to do this. Some fuels are less easily vaporized than others, and that is why it is advisable always to use No. 1 quality of one of the well-known brands of petrol, rather than to employ an inferior fuel in an endeavour to save a copper or two per gallon.

Briefly, the action of a carburettor is as follows.

Liquid petrol issues through a minute nozzle into a stream of rapidly moving air, by which process it is converted from liquid fuel into a highly atomized vapour. The upward stroke of the piston sucks this air stream through the carburettor, and the amount that is allowed to pass into the engine is controlled by the throttle slide. It is obvious that the strength of the mixture depends upon the proportion of fuel emerging from the jet, and the air passing through the carburettor.

In most instruments the size of jet is fixed, so that a set quantity of petrol with air, giving a certain proportion, is constantly fed to the engine. This proportion is determined for average running, but obviously it must be required to vary this according to different engine conditions, because at times a much richer mixture, i.e. a greater proportion of petrol in the air, may be needed.

In the Villiers instrument, the amount of petrol that is allowed to issue from the jet is automatically proportioned to the amount of air that is allowed to enter into the engine, from which it will be seen that this instrument must be more efficient, covering a wider range of varying engine conditions than would a carburettor with a fixed jet or nozzle.

A detailed description of the working of the Villiers carburettor is given as follows.

Construction. The Villiers carburettor gives a perfectly and automatically adjusted mixture over the whole range of throttle opening. This is achieved by means of its compensating action, which is very simple and involves the use of absolutely no moving parts.

Being entirely automatic in its operation, the instrument requires only one lever to control it. Such an arrangement is

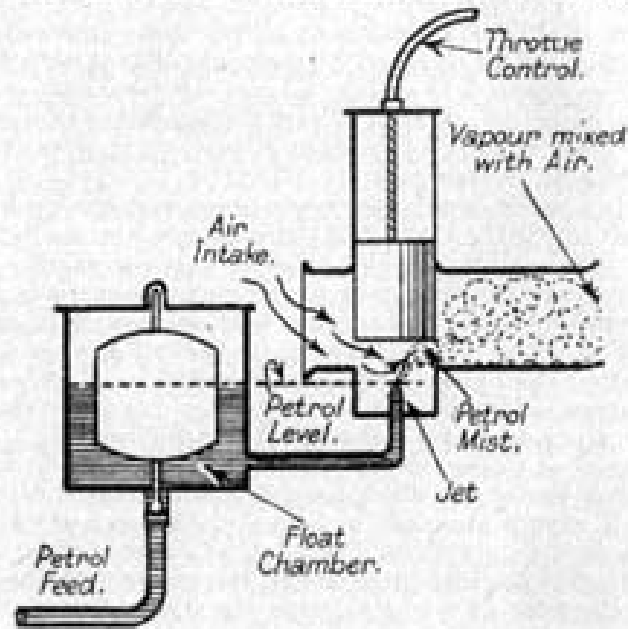

FIG. 50. DIAGRAM EXPLAINING THE PRINCIPLE OF CARBURATION

better than having one air and one throttle slide, each controlled with a separate lever, because with the latter arrangement the rider is always over-correcting his mixture. He finds the setting is a little too weak, and therefore closes his air lever. The effect of altering the air setting on an engine is not instantaneous, and, therefore, by the time the engine has settled down to the new air setting, it is found that the mixture is too rich and the lever has again to be opened a little. This goes on repeatedly, and the rider rarely has a proper mixture setting.

All this is obviated in the Villiers instrument, because there is only one lever to open and close the throttle, which, at the same time, enlarges or reduces the size of the jet by means of a taper needle attached to and working with the throttle.

An independent adjustment of this taper needle is provided to

give a specially rich mixture at times when it is required, such as when starting a cold engine. This independent adjustment is provided on some models by means of a rod (*d* in Fig. 51) having a quick-thread in the throttle, which is arranged to raise or lower the needle $\frac{1}{4}$ in. by one complete turn of the bar. On other models the needle is raised and lowered in the jet by means of a separate control (*D* in Fig. 52) operated from the handlebar

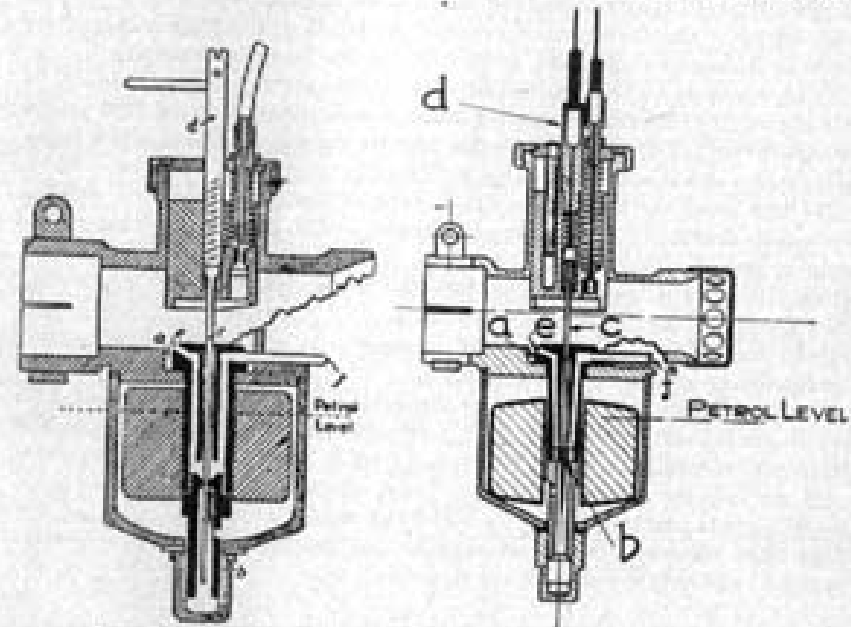

FIGS. 51 AND 52. SHOWING LEFT AND RIGHT, RESPECTIVELY, SECTIONAL VIEWS OF SINGLE AND DOUBLE LEVER CARBURATORS

The handlebar lever is marked "rich" and "weak" to indicate how the jet size is set. *On no account must this top lever be used as an ordinary "air control."* It should remain stationary except when deliberately wishing to alter the size of the jet.

The action of the carburettor is very simple, and reference to Figs. 51 and 52, showing sectional arrangements of the two types of carburettors, will make it quite clear. Depressing the float tickler creates a well of petrol at *a*, which, with the throttle open only a little, is drawn into the cylinder at the first kick, so giving very easy starting. The opening and closing of the throttle, as already explained, enlarges and reduces the size of the jet *b* by means of the taper needle *c*. The size of the jet may be enlarged independently of the throttle opening, to give a rich mixture when starting from cold, the "rich" and "weak" positions

being marked on the top disc of the carburettor, or on the handlebar lever top plate. When the engine is warmed up the needle is again lowered in the jet, to weaken the mixture as much as is consistent with good running. The position of the needle will then not require to be altered again until the engine is started from cold.

The automatic compensating action of the carburettor is as follows. Mixture is delivered by the carburettor in two different ways—firstly, by the suction of the engine on the orifice *e*, and secondly, by the force of the head of petrol through jet *b*. Since the jet *b* is below petrol level, petrol is always issuing from it.

The suction of the engine on the orifice *e* draws in a stream of air through the compensating tube *f* across the top of the jet *b*, where it mixes with and breaks up the petrol, and so issues from *e* into the main air stream as a partially atomized vapour.

If the load on the engine is increased, so reducing the engine speed, as for instance, when hill climbing, the suction on the orifice *e* is reduced. This would weaken the mixture but for the fact that the petrol issuing from jet *b* is constant, thereby richening the partially atomized vapour coming through *e*—the combined effect being that the mixture strength is maintained constant irrespective of engine speed or load.

As the main jet is in the centre of the float chamber the mixture is not upset by tilting the machine, and actually the motor-cycle must almost lie down before flooding will occur.

The Villiers carburettor has been improved by interposing a toggle arrangement between the float and fuel needle and is now fitted on all models. It is similar to the fitment on the heavy-weight carburettor shown on page 80.

Important. If the carburettor fitted to your machine is the Villiers model with two control levers on the handlebar, it cannot be too definitely emphasized that the top lever is not an air control as on other instruments, and must not be used as such. It is solely a lever for independently altering the size of the jet to give an extra rich mixture when required, such as when starting a cold engine.

On the single-lever Villiers carburettor, this control takes the form of a small bar on the top of the carburettor itself. Both should be turned toward "rich" only when starting from cold, and then should be kept as far towards the "weak" position as is consistent with good running.

Tuning for Best All-round Results. From the description of the instrument given it will be understood that it is self-regulated, and provided the correct jet and needle are fitted in the first place, the carburettor will give the right mixture at all throttle openings

and speeds, and the independent jet control should not need to be moved when the engine is warm until again starting from cold. By means of various sizes of needles this carburettor is adaptable to any type of engine, but various models require a different combination of jet and needle. The early Villiers carburettors had only one compensating tube (*f* in Fig. 51), but the later models are fitted with two compensating tubes. The following are the jets and needles used in the standard setting with each Villiers engine—

Type of Engine	Jet with Single Compensating Tube	Jet with Two Compensating Tubes	Needle
Mark I to V	-081	3	4%
147 c.c. Mark VI C and Mark VII C and Mark VIII C	-081	3	2½%
247 c.c. Mark VI A and Mark VII A	-081	3	2½%
247 c.c. Mark VIII A	-081	3	3½%
247 c.c. Mark IX A	-081	3	4%
342 c.c. Mark VI B and Mark VII B	-081	3	3½%
342 c.c. Mark VIII B	-081	3	3½%
342 c.c. Mark IX B	-081	3	3½%
172 c.c. Sports	-081	3	3½%
172 c.c. Sports (petrol lubrication)	-081	3	3½%
172 c.c. T.T. Super-sports	-081	3	3½%
196 c.c. Mark I E	—	—	3½%
247 c.c. Mark XA	—	—	3½%
342 c.c. Mark IXBA	—	—	3½%
125 c.c. Mark 2E	—	—	4%
196 c.c. Super-sports	—	—	4%
346 c.c. Long Stroke	—	—	4%
249 c.c. Mark XIV A	—	—	4%
249 c.c. Watercooled	—	—	4%
148 c.c. Mark XII C	—	—	4%
98 c.c. Midget	Midget	—	5½% (Special)
125 c.c. Unit	"	—	6% (Special)
98 c.c. "Junior"	87	—	1½% (Special)
249 c.c. Mark XVIIa (Heavyweight Carburettor)	51	—	2% (Special)

All needles are marked with the degree of taper on their side. The following sizes of needles are available: 1½, 2, 2½, 3, 3½, 4, 4½, 5, 6, and 7, but those given in the table above are the ones found most suitable for general running. Size -081 jets are marked with that figure on their head, but the other jet is marked with a figure on one of the flats of the hexagon, half way down the shank.

If it is necessary to write to the makers for any spare parts for a carburettor, always give particulars of the engine to which it is to be fitted.

To tune the carburettor, first obtain the most satisfactory position of the needle for slow running on the road when the engine is warm, by means of altering the jet control lever, and then open the throttle lever quickly. If the engine dies out it shows that the mixture is too weak, and a needle with a greater degree of taper should be fitted. If it is found possible to open it quickly and the engine is inclined to "hunt," the mixture is obviously too rich, and a needle with less taper should be fitted. Again, the mixture is shown to be too rich if the throttle is closed when running at speed and the engine hesitates, or momentarily ceases to fire. When the needle best suited for speed is obtained it will be the best one for economy and power. There is no definite rule as to the best running position of the jet lever, but it is wise to set it so that when turned as far as it will go to the weak position, the mixture is actually too weak to run. This means that for normal running it will have to be a little way towards rich, and will always give a margin of safety. Otherwise, if it were as far as it would go in the weak position, one would never be quite certain that one was running on the best setting. If necessary, in the case of the single-lever carburettor, the small bar should be unscrewed from the needle rod, and replaced in another hole at right angles to the previous one, so that the needle rod may be turned round farther.

In the case of the two-lever carburettor there is a screw with a locknut on the body of the handlebar control. By screwing this in the mixture is made weaker, and by screwing it out it is made richer. It is very necessary that at all times the compensating tubes are clear. Should one be lost, on no account must this be replaced by a screw or plug.

To Change the Needle—Single-lever Model. Unscrew the top cap on the body of the carburettor and remove the throttle. Unscrew the bar on the needle rod, and then the needle rod itself. Now by inverting the throttle, the needle with its small spring will fall out (see Fig. 53). Fit this small spring to the new needle you wish to install, making sure that the small coil of the spring is at the top of the needle, immediately under its head. Place the needle in the throttle, screw in the needle rod, and then replace the throttle in the body of the carburettor, making sure that the top disc is located by means of its tongue in the slot on the carburettor body before screwing down the top ring. Tighten the small bar in the needle rod after the correct adjustment has been obtained, so that this part does not work loose.



FIG. 53. REFITTING THE TAPER NEEDLE IN THE VILLIERS CARBURETTOR (EARLY TYPE)



FIG. 54. SHOWING HOW TO REMOVE THE TAPER NEEDLE FROM THE THROTTLE OF THE TWO-LEVER CARBURETTOR

Two-lever Model. This differs slightly in construction, and after the throttle is taken out of the carburettor the hexagon in which the cable takes its anchorage must be unscrewed. This will give access to the needle, which is then changed as on the single-lever model (see Fig. 54).

Dismantling and Reassembling the Carburettor. The instrument should not be dismantled before first detaching it from the engine. Unscrew the top ring and remove the throttle, then turn the carburettor upside down and unscrew the nut at the bottom of the float chamber. Take off the fibre washer, then lift off the

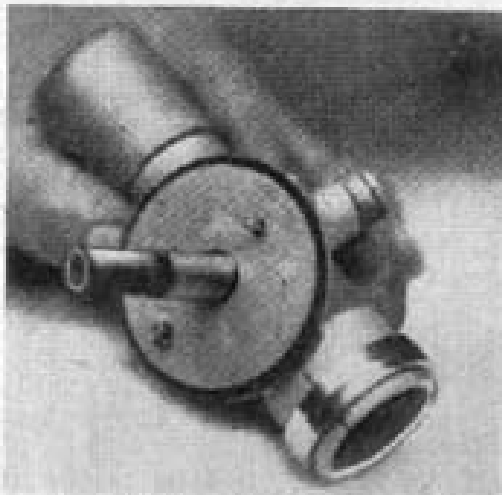

FIG. 55. FUEL NEEDLE IN POSITION (KARLISCH TYPE)

cup and the float. This will expose the small fuel needle, which should be carefully lifted out.

To remove the centre piece and jet, unscrew the compensating tube or tubes, and the former may then be pulled out. *Never unscrew the jet from the centre piece.*

When reassembling, clean each part carefully. First place the centre piece in position with the fibre washer under its head, then screw in the compensating tube, or tubes, carefully. Place the fuel needle in position, making sure that the *pointed end is inside* the carburettor body. Place the float on top of this, and then, after fitting the large fibre washer, put on the cup, then the small fibre washer, and screw the bottom nut into position. Tighten the latter with a spanner, but do not use too much force.

For some years now an improvement has been incorporated in the form of a damper spring fitted inside the throttle. This

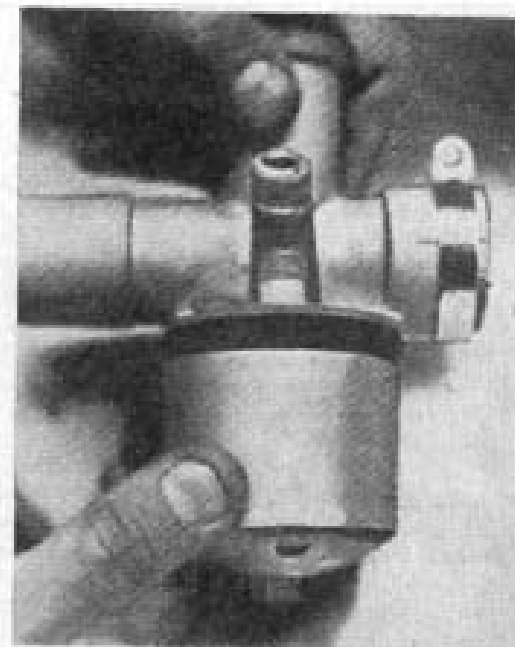

FIG. 56. WHEN DISMANTLING THE VILLIERS CARBURETTOR, BE CAREFUL THAT THE FUEL NEEDLE IS NOT LOST



FIG. 57. THE COMPENSATING TUBES IN THE VILLIERS CARBURETTOR MUST BE FREE FROM OBSTRUCTION

achieves the same object as the bulging of the rod to prevent jarring round of the needle rod, and has the advantage of being quite permanent and needing no further attention.

The Needle Rod in the Single-lever Instrument. If this rod loses its tension, and tends to turn round on its own accord, it should be taken out, and the slotted end of the thread may be

opened slightly so as to give the rod more tension. The best way of doing this is to place a small bar about $\frac{1}{8}$ in. in diameter in the slots, approximately $\frac{1}{4}$ in. from the end, and then close the ends of the rod together with a pair of pliers (see Fig. 58).

Villiers Single Lever Lightweight and Middleweight Models. These have an improvement in the needle

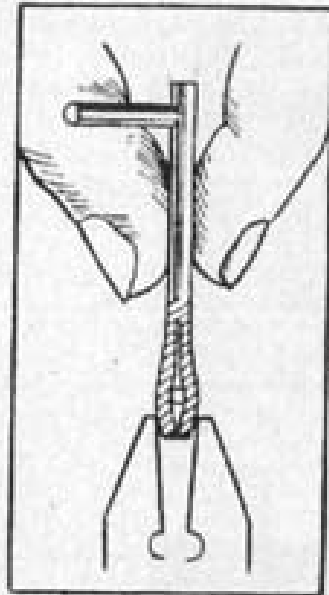

FIG. 58. TIGHTENING THE NEEDLE ROD



A



B

FIG. 59

rod, known as the "damper spring" type. The needle rod is held in position by a damper spring which prevents it moving except when turned by hand.

The needle rod is split at the quick-thread end, and into the split is inserted a special shaped spring, which in plan view looks like the letter S.

The top and bottom of the S press against the sides of a hole in the throttle slide, and thus by friction prevent the needle rod turning on its own accord, due to vibration. The damper spring is illustrated in Fig. 59 at A. This is prevented from falling out of the throttle by means of the damper screw, Fig. 59 at B.

When detaching the petrol pipe from the tank to the carburettor, this should be handled carefully, and the union nuts should never be wrenched.

Be sure the spanner is a good fit on the nuts, and, when undoing

the top union, it is advisable to get another spanner to hold the hexagon on the top, so that this does not unscrew with the pipe union.

When replacing the petrol pipe, tighten the top and bottom unions together. This is much easier than screwing one up perfectly tight and then endeavouring to get the other nipple into position.

The Air Cleaner. Such a fitment as this is always worth while on every machine, and if one is not fitted on your motor-cycle, the price is only 3s., and it is a good investment.

The air cleaner is fitted on to the air intake side of the carburettor, and prevents dirt and grit passing into the engine. It has a number of vanes on its outer face which give a spinning motion to the air, and a deflector inside flings it outwards, where it is trapped by a lip in the shell of the cleaner. Any particles of dust are ejected here, and the cleaned air passes without obstruction into the carburettor. There are no moving parts to get out of order, and no gauze which may clog. Consequently, this cleaner requires no attention.

If it were possible to see all the grit and dust which is trapped, the rider would get a better idea of the amount of foreign matter which must pass into the engine without a cleaner, and which finds its way into the bearings and will also damage the cylinder walls, apart from being deposited with the carbon.

The Villiers Midget Carburettor. This small carburettor is the result of very extensive tests carried out to find a simple and efficient carburettor. It has a minimum of adjustments. The design of the carburettor is similar in principle to the present Villiers larger models, yet modified in details to enable the absolute novice to get good results.

It gives perfectly correct mixture over the whole range of throttle opening, and this is achieved by its compensating action which is similar to the larger models. It is very simple and involves the use of no moving parts. Being entirely automatic, it only requires one lever to control it, and is much better than having one air and one throttle slide, each controlled by a separate lever. It eliminates a lot of trouble in correcting the mixture, which is essential in the majority of makes of carburettors. With the Villiers "Midget" carburettor there is only one lever, which opens and closes the throttle, and at the same time enlarges or reduces the size of the jet E by means of a tapered needle C, attached to and working with the throttle G. An independent adjustment of this tapered needle C is provided by taking out the throttle G and loosening the screw K. This will enable the needle

hole. This should be left in this position until the engine is slightly warm (or, a good sign, if the engine begins to four-stroke) when the plate should be lowered.

When on the road the automatic compensating action of the carburettor adjusts the strength of the mixture to the demands of load or speed as follows—

As the engine speed increases, the suction on the orifice *E* also increases, but owing to the fact that air offers less resistance than petrol, air is drawn through the compensating tube *F* across the jet *B*, mixing with the petrol issuing from this jet, and so gradually weakening the mixture. As the engine speed falls, such as when hill climbing, the suction on the orifice *E* also falls and, therefore, less air is drawn down the tube *F*. As the jet *B*, however, is below the petrol level, a constant mixture is maintained.

It will be seen from the above, that at no time does neat petrol pass into the engine from the orifice *B*, but only a mixed vapour of petrol and air, varying in strength according to the demand of the engine, and controlled automatically by the amount of air passing across the top of the jet *B*. As the main jet is in the centre of the float chamber, the mixture is not upset by tilting the machine, and actually the motor-cycle must almost lie down before flooding will occur. The automatic compensating action, which is the principal feature of the Villiers carburettor, gives remarkable flexibility and great economy, because the engine is working more efficiently, as it has the correct mixture strength at all times.

The Midget Carburettor, in common with the Lightweight and Middleweight types, has a toggle control to the fuel needle which gives an increase in leverage over the old design and consequently overcomes any tendency to flood.

If it becomes necessary to remove the fuel needle, proceed as follows: unscrew the top ring and remove throttle, next unscrew compensating tube from centre piece. The compensating tube has a slotted end which is exposed after the removal of air filter. Remove bottom nut which secures the float. The centre piece can then be pushed upwards until the toggle can swing to one side, when the fuel needle will drop.

The Villiers Junior Carburettor. This carburettor is fitted on the Junior Engine, and the principle is exactly the same as the Midget type carburettor, but a different method is used for the adjustment of the needle. To adjust the needle, first of all remove throttle by unscrewing the top ring. At the head of the throttle there is a small screw; turning this in a clockwise direction, which lowers the needle, will give a weaker setting. Turning in an anti-clockwise direction will give a richer setting. For

adjustment, give approximately half a turn at a time until found to be correct.

To dismantle carburettor, proceed as for the Midget type, except that the centre piece is located by a small screw at the bottom and outside of the throttle chamber.

The Villiers Heavyweight Type Carburettor (used with the Mark XVII A engine).

To Start Engine from Cold. Press tickler (*T*) Fig 60A (*b*), until flooding occurs, open jet control level to full rich position, and open throttle about one-third. One or two kicks on the starter should start the engine. When warm close jet lever as required until in set position at bottom of slide.

Pilot Jet. This jet (*a*) governs the carburettor up to approximately one-quarter throttle; to enrich, screw clockwise.

Needle (N). No. 2 is fitted as standard to suit conditions in England. If the acceleration is poor, raise needle; if acceleration is still poor fit No. 3 needle. If the engine four-strokes at one-third throttle opening, the mixture is too rich. Fit No. 1 needle.

Main Jet (J). This jet (*a*) governs "all out" speed, and has no effect on small throttle openings.

To adjust the needle unscrew the top sleeve (*S*) out of the slide, and withdraw needle control complete. Extract small "U" shaped wire (*W*) and re-insert in another groove in needle, raising latter to get richer, and lower to get weaker.

Needles are marked one, two, etc., on the extreme top.

Petrol filter (*F*) should be cleaned periodically or petrol will not flow freely. On no account should it be taken off union, or grit, etc., will get into the needle seating (*C*) and cause flooding. Keep the air filter gauze (*G*) clear of dirt, etc., by washing in petrol.

A Few Carburettor Troubles and their Causes—Constant Flooding. This may be due to a punctured float which allows the petrol to find its way inside, and therefore makes it too heavy, and so causes the float chamber to fill and overflow. Or, to dirt on the seating of the fuel needle, preventing it from closing properly.

If the float is punctured, it is as well to replace it, because repairing it with solder may make it too heavy.

Another reason for flooding may be the "tickler" jamming down, caused by grit being thrown on to it from the road. To free it, tap gently and pull the tickler up. Clean carefully.

Spitting Back. This is the symptom of too weak a mixture, and may be caused by—

(a) Incorrect setting of the control levers, in which case the jet control must be set further towards "rich."

- (b) The fuel needle stuck in its seating, preventing petrol flowing to the carburettor.
- (c) A choked petrol pipe.
- (d) Water in the petrol.

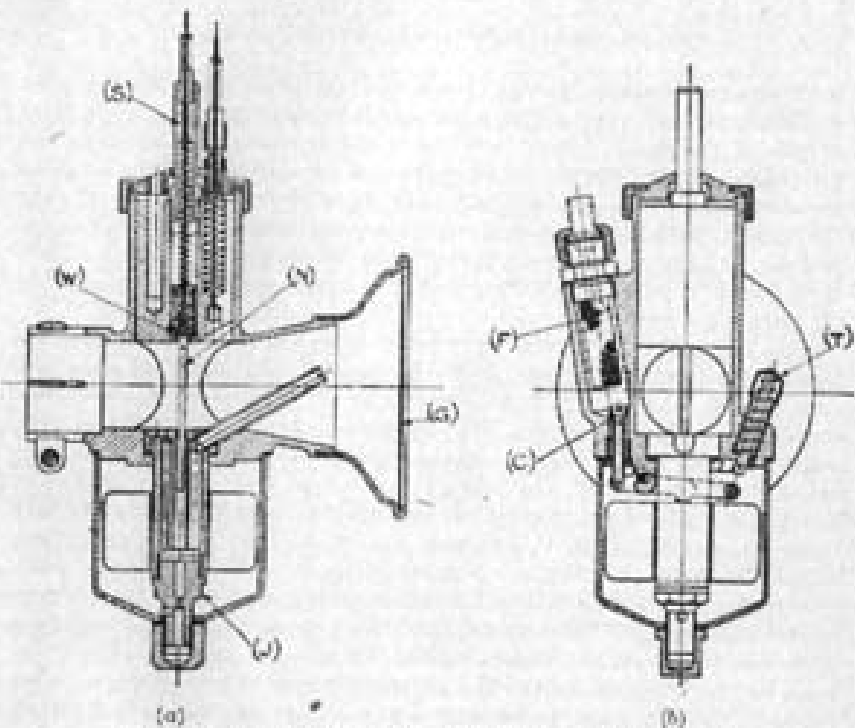

FIG. 60A. THE VILLIERS HEAVYWEIGHT CARBURETTOR.

N.B. It is impossible for a choked jet to occur on the Villiers carburettor, owing to the needle which constantly works inside the jet.

(e) The vent hole in the petrol tank choked.

There is usually a small hole in the filler tank to allow air to pass into the petrol tank to compensate for the petrol drawn out. If this is choked, a partial vacuum will be created in the tank and obstruct the flow of petrol.

Carburettor will Not Shut Off. This may be due to the throttle sticking, probably through mud or grit causing it to bind. This would be prevented if an air cleaner were fitted. Another cause may be a damaged control cable, preventing the inner wire from moving freely in the outer cable.

www.podkowa98.pl

www.wul-gum.podkowa98.pl

**ZAPRASZA
na swoje strony**